



Bank Note Paper Mill India Private Limited
Registered & Corporate office: Administrative Building
Gate 1, Paper Mill Compound, Note Mudran Nagar
Mysuru-570 003 Karnataka, India

Standard Biding Document (SBD)

Not Transferable

Tender Document for – **Supply of Centrifugal Blower Assembly for Bale Plucker with Motor**

Tender No. BNPM/TEN/Blower Assembly/368/2017-18, Dated: 24.01.2018

The Tender Document contains **42** Pages

The Tender Document is sold to

M/s
Address

Details of Contact person in BNPM regarding this tender

Name: Alok Kumar

Designation: Deputy General Manager

Address **Bank Note Paper Mill India Pvt. Ltd.**
Administrative Building, Gate 1, paper Mill Compound
Note Mudran Nagar,
Mysore- 570003.
Phone 0821- 2401 171/174; Fax 0821 2401 222
Email: alokkumar@bnpmindia.com / bhoodhar@bnpmindia.com
Website: www.bnpmindia.com



CONTENTS - STANDARD BIDDING DOCUMENT

Section No	Specification no	Description
	APQ	Application- Pre-qualification
I.	BNPM/TEN/Blower assembly/368 /2017-18	Notice Inviting Tender (NIT)
II.	GIT	General Instructions to Tenderers - To be download from website
III.	SIT	Special Instructions to Tenderers - To be download from website
IV.	GCC	General Conditions of Contract
V.	SCC	Special Conditions of Contract
VI.	LOR	List of Requirements
VII.	TS	Technical Specifications
VIII.	QCR	Quality Control Requirements
IX.	QC	Qualifying/ Eligibility Criteria
X.	TF	Tender Form/ Acceptance of Terms & Conditions
XI.	PS	Price Schedule
XII.	QUEST	Questionnaire
XIII.	BG-EMD	Bank Guarantee Form for EMD Not Applicable
XIV.	MAF	Manufacturer's Authorization Form Not Applicable
XV.	BG-PS	Bank Guarantee Form for Performance Security.
XVI.	CF	Contract Form- Not Applicable
XVII.	LOA	Letter of Authority for attending Bid Opening
XVIII.	SA	Shipping Arrangements for Liner Cargoes Not Applicable
XIX.	PBP	Proforma of Bills for Payments Not Applicable
XX.	APQ	Application-Pre-Qualification
XXI.	ACW	Additional Conditions of Works Contract - Not Applicable
XXII.	IP	Proforma for Integrity Pact - Not Applicable

NIT	BANK NOTE PAPER MILL INDIA PRIVATE LIMITED	SECTION: I
	NOTICE INVITING TENDER	SHEET 1 OF 3

BANK NOTE PAPER MILL INDIA PRIVATE LIMITED
 Administrative Building, Entry Gate 1, Paper Mill Compound,
 Note Mudran Nagar, Mysuru-570003, Karnataka, India
 Tele: 0821-2401 111, 171, 174, Fax 0821-2401 154
 Email bhoodhar@bnpmindia.com, website: www.bnpmindia.com

BNPM/TEN/Blower Assembly/368/ 2017-18, Dated: 24.01.2018

1. Tenders are invited in two parts (Techno-commercial & Financial) from eligible and qualified tenderers for supply of following Goods: Bidders satisfying the technical and commercial conditions specified in the bid and ready to supply the mentioned products in conformity with the Scope of Supply and Technical specification provided in NIT and terms and conditions stipulated herein may submit their commercial quotes as specified in the format of the document.

S No.	Brief Description of Goods/ Services	Qty	Earnest money
1.	Supply of Centrifugal blower assembly for bale plucker with motor	1 SET	INR 5,000/- (Rupees Five Thousand only)

Earnest Money Deposit (EMD):

The tenderers who are currently registered and also will continue to remain registered during the tender validity period with DGS&D or with National Small Industries Corporation/ MSME are exempted from payment of earnest money. In case the tenderer falls in these categories, it should furnish certified copy of its valid registration details (with DGS&D) or NSIC or MSME as the case may be).

Tender Number	BNPM/TEN/Blower Assembly/368/2017-18, Dated: 24.01.2018
Type of Tender (Two Bid/PQB/EOI Etc.)	Two Bid
Details of Sales of tender Documents	
Price of the tender Documents	Rs 1000/-
Closing Date and time for receipt of tenders	09.02.2018, 1500 Hours
Pre-bid meeting	N/A



NIT	BANK NOTE PAPER MILL INDIA PRIVATE LIMITED	SECTION: I
	NOTICE INVITING TENDER	SHEET 2 OF 3

Place of receipt of tender	Bank Note Paper Mill India Pvt. Ltd. Administrative Building, Gate 1, Paper Mill Compound Note Mudran Nagar, Mysore- 570003.
Time and Date of opening of tender	09.02.2018, 1600 hours
Place of opening of tenders	Bank Note Paper Mill India Pvt. Ltd. Administrative Building, Gate 1, Paper Mill Compound Note Mudran Nagar, Mysore- 570003.
Nominated Person/Designation to receive the bulky tender (Clause 21.1 of GIT)	Shri Bhodhar Prasad Kewat, AM Shri Alok Kumar, DGM

2. Interested tenderers may obtain further information about this requirement from the above office selling the documents. They may also visit our website www.bnpmiindia.com for further details, addenedun/corrigendum etc.
3. The tender document may be purchased on payment of non-refundable tender fee of Rs. 1000/- per set in the form of account payee demand draft on a schedule commercial bank in India, in favour of Bank Note Paper Mill India Private Limited payable at Mysore or Electronic Transfer. EMD may also be transferred to BNPM account.
4. If requested, the tender document will be mailed by registered post/speed post to the domestic tenderers, for which extra expenditure per set will be Rs 200 for domestic post. The tenderer is to add the applicable postage cost in the non refundable fee mentioned above in Para 3 above.
5. Tenders may also visit website www.bnpmindia.com or contact BNPM for further information/details.
6. The tender shall contain two sealed envelopes each of whose contents shall be as follows.
7. The tender shall contain three sealed envelopes each of whose contents shall be as follows.
 - a) **Sealed envelope super-scribed Envelope-1, consisting of**
 - i) Bid forwarding letter.
 - ii) Power of Attorney in favour of the person who has signed the bid on stamp paper of appropriate value.



NIT	BANK NOTE PAPER MILL INDIA PRIVATE LIMITED	SECTION: I
	NOTICE INVITING TENDER	SHEET 3 OF 3
<p>iii) Documents to establish conformity with Bidder's Qualification/Eligibility criteria. (As per eligibility criteria)</p> <p>iv) ESIC, PAN details, GST registration certificate, Scheduled bar chart, proposed organization chart.</p> <p>v) Cost of bidding document in the form of crossed Demand draft in a separate envelope (Applicable for bidders who have downloaded the bids from BNPM's website)/ Electronic Transfer</p> <p>vi) Earnest Money Deposit – in separate envelope</p> <p>vii) Deviations from GCC, SCC, SIT, GIT (if any)</p> <p>viii) Schedule of deviations to technical specifications separately</p> <p>ix) Technical details/documents specified in technical part</p> <p>x) Blank copy (Without price) of Schedule of price duly signed & stamped on each page</p> <p><i>The envelope shall be super scribed as- "ENVELOPE-1- Prequalification & Technical Bid" along with the name of work.</i></p> <p>b) Sealed envelope super-scribed Envelope-2, shall contain.</p> <p>i) Bid forwarding letter.</p> <p>ii) Schedule of Prices duly filled in.</p> <p><i>The envelope shall be super scribed as- "ENVELOPE-2- Financial Bid" along with the name of work</i></p> <p>The three sealed envelope shall be put in a separate sealed envelope super-scribed as "Tender for Supply of Centrifugal Blower Assembly for Bale plucker with Motor – Tender No: BNPM/TEN/Blower Assembly/368/ 2017-18, Dated: 24.01.2018 not to be opened before 09.02.2018"</p> <p>8. Tenderers shall ensure that their tenders, duly sealed and signed, complete in all respects as per instructions contained in the Tender Documents, are dropped in the tender box located at the address given below on or before the closing date and time indicated in the para 1 above, failing which the tender will be treated as late and rejected..</p> <p style="text-align: center;">Bank Note Paper Mill India Pvt. Ltd. Administrative Building, Gate 1, Paper Mill Compound Note Mudran Nagar, Mysore- 570003 Karnataka, India</p> <p>9. In the event of any of the above mentioned dates being declared as a holiday / closed day for the purchase organisation, the tenders will be sold / received / opened on the next working day at the appointed time.</p>		



NIT	BANK NOTE PAPER MILL INDIA PRIVATE LIMITED	SECTION: I
	NOTICE INVITING TENDER	SHEET 4 OF 3

10. The tender documents are not transferable.

Yours Faithfully,

(Alok Kumar)
Deputy General Manager



PART 1: GENERAL INSTRUCTIONS APPLICABLE TO ALL TYPES OF TENDERS

This section-II shall be downloaded from website: www.bnpmindia.com under
thesection

“Procurement -> Downloads ” and signed & stamped and submitted along with the
Techno- Commercial Bid –Part II as acceptance of terms and conditions.

(Offer without the copies of section-II shall liable to be rejected).

SIT	BANK NOTE PAPER MILL INDIA PRIVATE LIMITED	SECTION: II
	SPECIAL INSTRUCTIONS TO TENDERERS	SHEET 1 OF 2

The following Special Instructions to Tenderers will apply for this tender. These special instructions will modify/ substitute/ supplement the corresponding General Instructions to Tenderers (GIT) incorporated in tender. The corresponding GIT clause numbers have also been indicated in the text below: In case of any conflict between the provision in the GIT and that in the SIT, the provision contained in the SIT shall prevail.

Sl No	GIT Clause No	Topic	Substitution / Replaced by
1.	18.0	Earnest Money Deposit	4.0
2.	35.0	Evaluation Criteria	5.0

1.0 Corrigendum/ Addednum, if any, including clarifications provided during pre-bid meeting/or otherwise shall be hosted on Company's website (www.bnpmindia.com) only.

2.0 The Company discourages the engagement of agents for brokering contracts and hence intending bidders are requested to take note of the above that engagement of agents for brokering contracts may result in dis-qualification.

3.0 Earnest Money Deposit (EMD):

The tenderers who are currently registered and also will continue to remain registered during the tender validity period with DGS&D or with National Small Industries Corporation/ MSME are exempted from payment of earnest money. In case the tenderer falls in these categories, it should furnish certified copy of its valid registration details (with DGS&D) or NSIC or MSME as the case may be).

The EMD of unsuccessful bidders shall be returned on finalization of the tender/ order. The EMD of successful bidder shall be returned on receipt of performance security deposit/ completion of contract period.

3.1 Important Dates: -

Final Date of Submission of tenders: - **09.02.2018, 1500 Hours**

Opening of Envelope 1 and Envelope 2 **09.02.2018, 1600 Hours**
(Prequalification and Technocommercial bids)

Opening of Financial Bids to be announced later

4. EVALUATION CRITERIA:

(i) Techno-commercial bid / Pre Qualification bid shall be opened together and however, the Techno-commercial bid of pre-qualified bidder who meets the



eligibility criteria shall be scrutinised and evaluated by the competent committee/ authority with reference to the parameters prescribed in the tender document. Subsequently, in the second stage the financial bids of only technically acceptable offers as decided in first stage shall be opened for further scrutiny and evaluation. Intimation regarding opening of financial bids shall be given to acceptable tenderers to enable them to attend the financial bid opening, if they so desire.

- (ii) The method of evaluation of bidder for awarding the Contract shall be on consolidated grand total offered by the bidder and will be decided taking into consideration of the total offered price for delivery up to BNPM, Mysore (Without GST)

Following clauses in GIT are not applicable.

Sl No	GIT Clause No	Topic	Substitution / Replaced by
1.	14.2, 14.3, 14.4, 14.5, 14.6, 14.7	Firm Price/ Variable Price	Not Applicable
2.	50	Rate Contract Tenders	Not Applicable
3.	53	Expression of Interest (EOI) Tenders	Not Applicable
4.	54	Tenders for Disposal of Scrap	Not Applicable
5.	55	Development and indigenization Tenders	Not Applicable
6.	43.0	Parallel Contract	Not Applicable
7.	52.0	Tenders Involving Samples	Not Applicable

PART 1: GENERAL CONDITIONS OF CONTRACT APPLICABLE TO ALL TYPES OF TENDERS**Section IV: General Conditions of Contract (GCC)**

This section-IV shall be downloaded from website: "www.bnpmindia.com" under the Section "Procurements -> Downloads" and signed & stamped and submitted along with the Techno-Commercial Bid -Part II as acceptance of terms and conditions.



The following Special Conditions of Contract (SCC) will apply for this purchase. The corresponding clauses of General Conditions of Contract (GCC) relating to the SCC stipulations have also been incorporated below. These Special Conditions will modify/substitute/supplement the corresponding (GCC) clauses.

Whenever there is any conflict between the provision in the GCC and that in the SCC, the provision contained in the SCC shall prevail.

(Clauses of GCC listed below include a possibility for variation in their provisions through SCC. There could be other clauses in SCC as deemed fit)

Sl No	GCC Clause No	Topic	Substitution/ Replaced by
1	10	Delivery Schedule	1.0
2	22, 22.1, 22.2, 22.3, 22.4, 22.6	Payment Terms	2.0
3	36	Integrity Pact	Not Applicable

1. Delivery Schedule

- (i) Delivery shall be made within 4-6 weeks from the date of issue of purchase order.
- (ii) It is responsibility of the supplier to arrange transportation and supply the material FOR destination basis. BNPMIPL requires material on FOR site office, Note Mudran Nagar, Mysore Basis only. The quoted price should be inclusive of Transit Insurance.

2. Payment Terms & Performance Security

- a. 90% on receipt and acceptance of goods by the consignee at destination and on production of all required documents by the supplier.
- b. 10% of supply value shall be retained as performance security till completion of warranty period, however this amount may be released on submission of performance bank guarantee of equivalent amount with a validity of 1 year.

Payments to the suppliers shall be made through ECS in INR only.

Materials not meeting our specification will be rejected outright and the rejected material shall be taken back within 7 days at the cost and risk of the supplier and replacement should be made within 7 days from the date of intimation. No payment shall be made for rejected item.



LOR**BANK NOTE PAPER MILL PRIVATE LIMITED**

SECTION: VI

LIST OF REQUIREMENTS

SHEET 1 OF 1

S.No	Brief Description of Goods	Qty with units	Earnest Money Deposit
01	Centrifugal Blower assembly for Bale Plucker with motor	01 SET	Rs. 5,000/- (Rupees Five Thousand only)



Technical Specification	
--------------------------------	--

Item	Blower Assembly
Required air flow rate	10,000 m ³ / hr (min)
Head	Min 385 mmwc to 450 mmwc
Temperature at which air enters	Atmospheric temperature (25-30 ° C)
Application	To convey cotton of 450 kg/ m ³ bulk density.
Material flow rate	1500 Kg/hr
Blower impeller	should be dynamically balanced with balancing certificate (existing impeller 560mm)
No of blades on impeller	6 Nos
MOC of the Impeller	MS / Aluminium Alloy
MOC of blower casing	MS 5mm Thick
Speed of motor	3000 RPM
Motor Power	30 KW
Suction Size	350mm ID circular as per drawing
Delivery size	Rectangle shape 335 x 440 mm (as per drawing)
Drive	Directly connected with motor shaft
Dimensions	As per attached drawing
MOC of Fan	MS ; 5mm thick (min)
Paint of the Fan Body	Blue
Motor Make	Siemens
Warranty	Minimum of 1 year
Test certificate	Required

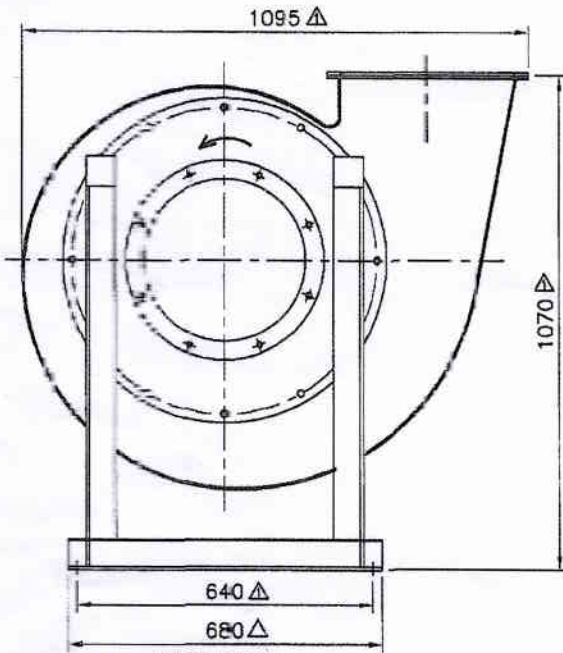

VIEW FROM SUCTION SIDE

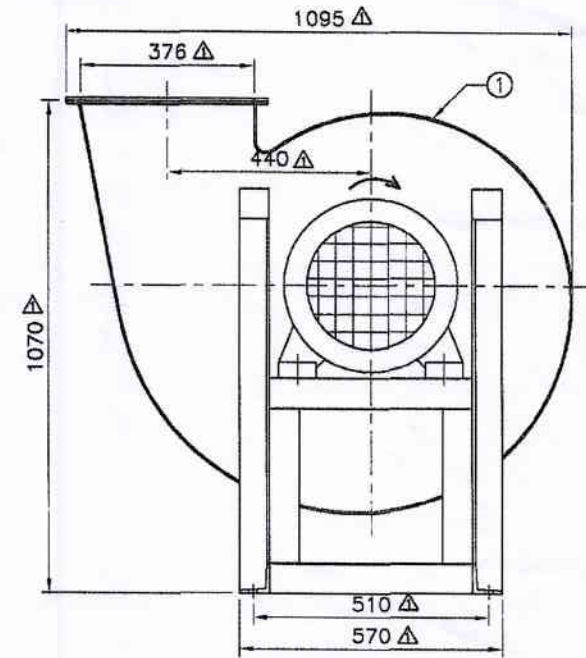
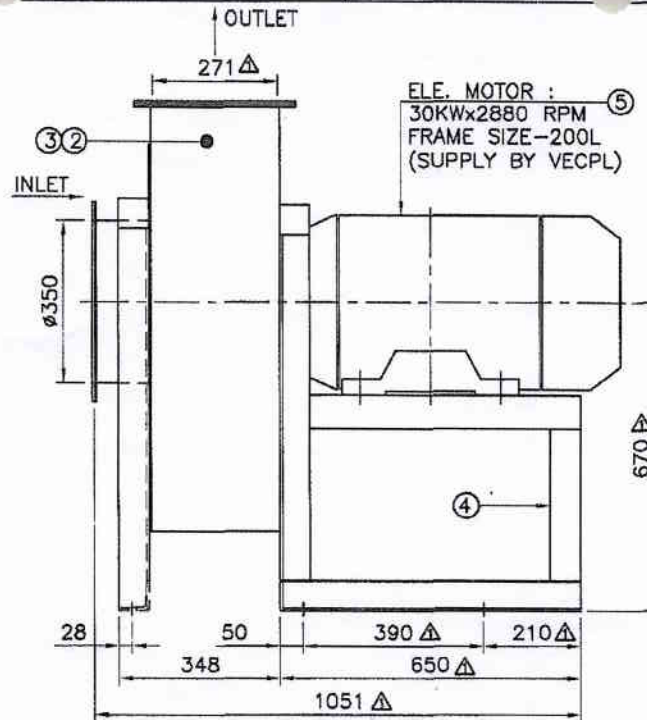

VIEW FROM DRIVE SIDE

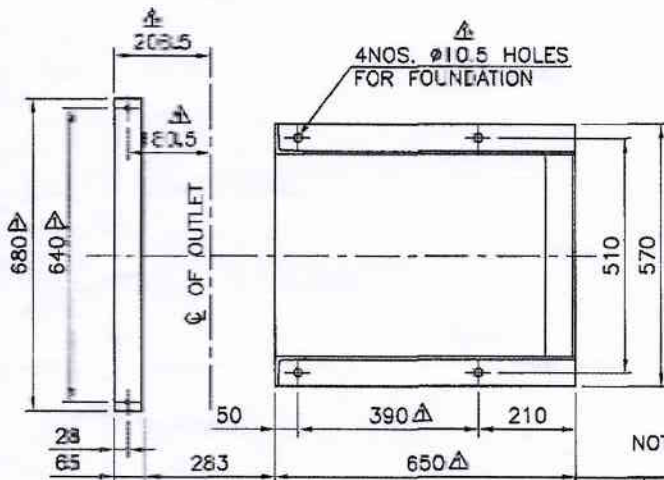

FOUNDATION PLAN

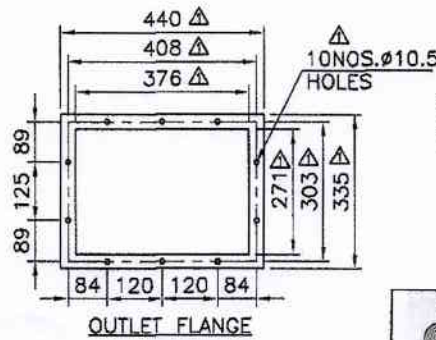

OUTLET FLANGE

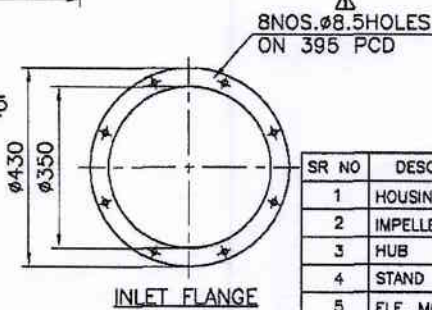

INLET FLANGE

PART LIST

SR NO	DESCRIPTION	MATERIAL/MAKE
1	HOUSING (5MM)	MS-IS 2062
2	IMPELLER (B/P-8MM, BLADE-6MM)	MS-IS 2062
3	HUB	MS
4	STAND	MS-IS 2062
5	ELE. MOTOR (30KWx2880 RPM)	SIEMENS/CGL ABB/BBL

BANK NOTE PAPER MILL INDIA PRIVATE LIMITED
MYSORE-570003

Prep. By	Sign	Date	SUCTION BLOWER FOR BALE PLUCKER
	Ckd. By		
App. By	<i>[Signature]</i>	07/01/18	BNPM/PP/027/2018
			Rev. 00

Sheet - 1 OF 1



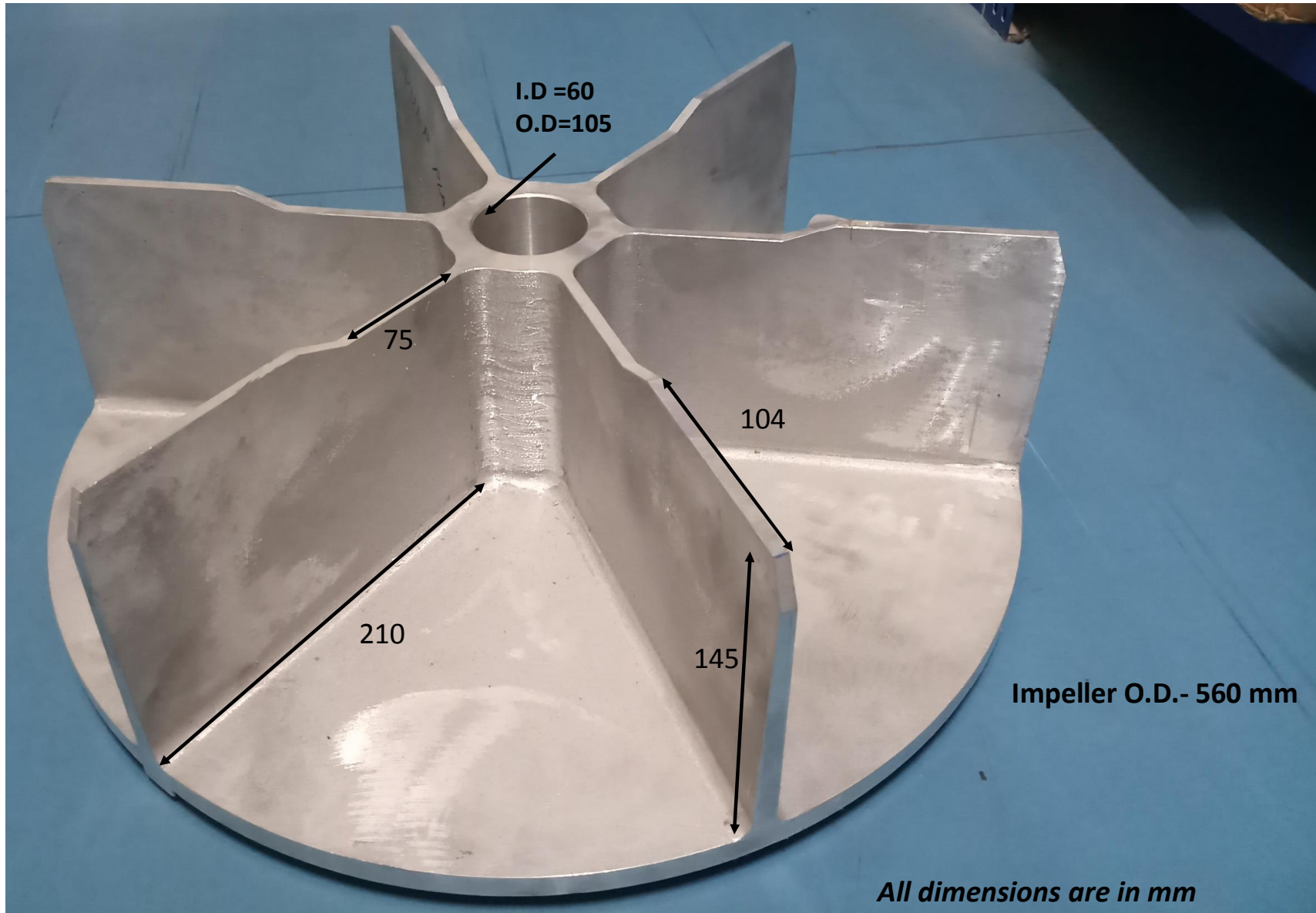

Quality control requirements must be in accordance with Technical Specification (Section VII) mentioned in this tender document.



The pre-qualification criteria for the same are given as under:

Individual/ firm/ company/ corporate other than limited company intending to bid should be bonafide, experienced, technically competent, resourceful and financially sound to carry out the assigned order.

The bidder should be:-

- a) Registered under GST.
- b) Having valid permanent Income Tax A/c No. as allotted by the Income Tax Authority of Government of India.
- c) Not blacklisted/ debarred by BNPM/ Bharatiya Reserve Bank Note Mudran (P) Limited (BRBNMPL) / Security Printing & Minting Corporation of India Limited (SPMCIL) or any Govt. Departments
- d) Firm should be financially sound and not a loss making company more than one year.
(Enclose financial statements of financial year 2014-15, 2015-16, 2016-17).
- e) The firm should have supplied atleast one blower during the last five years period ending 31.12.2017.

Note -1:

All experience, past performance and capacity/ capability related/ data should be certified by the authorised signatory of the bidder firm. The credentials regarding experience and past performance to the extent required as per eligibility criteria submitted by bidder may be verified from the parties for whom work has been done.

Scanned Documents to be submitted in support of Pre-qualification Criteria

The following documents should be submitted by the firm to prove the pre-qualification criteria.

- a) Company's Profile including details along with copy of following documents:
 - i. Certificate of Incorporation/ Registration
 - ii. Constitution of business, in case of business in individual name
 - iii. Partnership deed , in case of partnership
 - iv. Memorandum of Association and Articles of Association, in case of Limited company
 - v. Memorandum of Association by corporate other than Limited company
- b) In support of technical standing copy of purchase order/ work order/ agreement and/ or work completion certificate issued by competent authority of the customer duly certified by authorised signatory.
- c) In support of financial standing copies, audited balance sheets and Profit & Loss account should be certified by authorised signatory. In case of unaudited balance sheet, same should be certified by certified accountant's e.g. Chartered

QC**BANK NOTE PAPER MILL INDIA PRIVATE LIMITED**

SECTION: IX

QUALIFICATION/ELIGIBILITY CRITERIA

SHEET 2 OF 2

Accounts (CA) in India and Certified Public Accountant/ Chartered Accountants of other countries.

- d) Declaration that the firm has not been blacklisted/ debarred by BNPMIPL/ BRBNMPL /SPMCIL or any Govt. Departments during last three years duly signed by authorised signatory. (Annexure I)
- e) Declaration Acceptance of terms & conditions of tender (Annexure 2)
- f) Compliance Format (Annexure III)
- g) Copies of PAN, GST and Professional Tax Certificates etc. to be submitted along with the bid.
- h) Format for the annexures indicated in the preceding paragraphs are available in section XX which the bidder may refer to.
- i) Any other relevant document the firm wishes to submit



TF	BANK NOTE PAPER MILL INDIA PRIVATE LIMITED	SECTION: X
	TENDER FORM (ACCEPTANCE OF TERMS & CONDITIONS)	SHEET 1 OF 1

To _____ Date _____

Bank Note Paper Mill India Private Limited
 Administrative Building, Entry Gate 1, Paper Mill Compound,
 Note Mudran Nagar,
 Mysuru-570003, Karnataka, India

Ref: Your Tender document No.....dated.....

We, the undersigned have examined the above mentioned tender enquiry document, including amendment No. -----, dated ----- (if any), the receipt of which is hereby confirmed. We now offer to supply and deliver..... (description of goods and services) in conformity with your above referred document for the sum as shown in the price schedule(s), attached herewith and made part of this tender.

If our tender is accepted, we undertake to supply the goods and perform the services as mentioned above, in accordance with the delivery schedule specified in the List of Requirements.

We further confirm that, if our tender is accepted, we shall provide you with a performance security of required amount in an acceptable form in terms of GCC clause 6, read with modification, if any, in Section V- "Special Conditions of Contract", for due performance of the contract.

We agree to keep our tender valid for acceptance for a period up to -----, as required in the GIT clause 19, read with modification, if any in Section-III -"Special Instructions to Tenderers" or for subsequently extended period, if any, agreed to by us. We also accordingly confirm to abide by this tender up to the aforesaid period and this tender may be accepted any time before the expiry of the aforesaid period. We further confirm that, until a formal contract is executed, this tender read with your written acceptance thereof within the aforesaid period shall constitute a binding contract between us.

We further understand that you are not bound to accept the lowest or any tender you may receive against your above-referred tender enquiry.

(Signature with date)

(Name and designation)

Duly authorized to sign tender for and on behalf of

Bidder shall use this covering letter while submitting the tender



PS

BANK NOTE PAPER MILL INDIA PRIVATE LIMITED

SECTION: XII

PRICE SCHEDULE

SHEET 1 OF 2

Sl. No. A	Description of goods B	UOM C	QTY D	Unit Price in INR E	P&F, if any F	Value in INR G=(D*(E+F))
1	Centrifugal Blower assembly for Bale Plucker with motor (As per specification & drawing mentioedn in tender section -VII	SET	1			
	Total value in words (

Note:-

1. Applicable GST @.....paybale extra at actuls.
2. Price is to be quoted strictly as per the above format.
3. Total value with GST Rs.....
4. Price shall be inclusive of packing, forwarding and insurance and door delivery basis.
5. Evaluation shill be done on overall L1 basis without considering the GST value.

Signature of the tenderer with company seal



QS	BANK NOTE PAPER MILL INDIA PRIVATE LIMITED	SECTION: XII
	QUESTIONNAIRE	SHEET 1 OF 1

The tenderer should furnish specific answers to all the questions/ issues mentioned below. In case a question/ issue does not apply to a tenderer, the same should be answered with the remark "not applicable".

Wherever necessary and applicable, the tenderer shall enclose certified copy as documentary proof/ evidence to substantiate the corresponding statement.

In case a tenderer furnishes a wrong or evasive answer against any of the under mentioned question// issues, its tender will be liable to be ignored.

1. Brief description of goods and services offered:
2. Offer is valid for acceptance up to
3. Your permanent income tax A/c no. as allotted by the Income Tax Authority of Government of India
(Please attach certified copy of your latest/ current Income Tax clearance certificate issued by the above authority)
4. Status:
 - a) Are you currently registered with the Directorate General of Supplies & Disposals (DGS&D), New Delhi, and/ or the present BNPMIPL and/ or the Directorate of Industries of the concerned State Government for the goods quoted? If so, indicate the date upto which you are registered and whether there is any monetary limit imposed on your registration.
 - b) Are you currently registered under the Indian Companies Act, 1956 or any other similar Act?
(Please attach certified copy (s) of your registration status etc. in case your answer (s) to above queries is in affirmative.
5. Please indicate name & full address of our Banker(s)
6. Please state whether business dealings with you currently stand suspended/ banned by any Ministry/ Dept of Government of India or by any State Govt.

.....

(Signature with date)

(Full name, Designation & address of the person duly authorised sign on behalf of the tenderer)

For and on behalf of

.....

(Name, address and stamp of the tendering firm)

ISSUE R0



**BG-
EMD**

BANK NOTE PAPER MILL INDIA PRIVATE LIMITED

SECTION: XIII

BANK GUARANTEE FORM FOR EMD

SHEET 1 OF 1

NOT APPLICABLE



MAF

BANK NOTE PAPER MILL INDIA PRIVATE LIMITED

SECTION: XIV

MANUFACTURER'S AUTHORIZATION FORM

SHEET 1 OF 1

NOT APPLICABLE



BG-PS

BANK NOTE PAPER MILL INDIA PRIVATE LIMITED

SECTION: XV

BANK GUARANTEE FORM FOR PERFORMANCE SECURITY

SHEET 1 OF 2

BANK GUARANTEE FORM FOR PERFORMANCE SECURITY

..... (Insert: Bank's Name, and Address of Issuing Branch or Office)

Beneficiary:

Administrative Building, Entry Gate 1, Paper Mill Compound,
Note Mudran Nagar,
Mysuru-570003, Karnataka, India

Date:.....

Performance Guarantee No.:

WHEREAS.....(name and address of the supplier) (hereinafter called "the supplier") has undertaken, in pursuance of LOI (Letter of Intent) no..... dated to supply (description of goods and services) (herein after called "the contract").

AND WHEREAS it has been stipulated by you in the said LOI that the supplier shall furnish you with a bank guarantee by a scheduled commercial bank recognized by you for the sum specified therein as security for compliance with its obligations in accordance with the LOI;

AND WHEREAS we have agreed to give the supplier such a bank guarantee;

NOW THEREFORE we hereby affirm that we are guarantors and responsible to you, on behalf of the supplier, up to a total of (amount of the guarantee in words and figures), and we undertake to pay you, upon your first written demand declaring the supplier to be in default under the contract and without cavil or argument, any sum or sums within the limits of (amount of guarantee) as aforesaid, without your needing to prove or to show grounds or reasons for your demand or the sum specified therein.

We hereby waive the necessity of your demanding the said debt from the supplier before presenting us with the demand. We further agree that no change or addition to or other modification of the terms of the contract to be performed thereunder or of any of the contract documents which may be made between you and the supplier shall in any way release us from any liability under this guarantee and we hereby waive notice of any such change, addition or modification.

We undertake to pay Bank Note Paper Mill India Private Limited up to the above amount upon receipt of its first written demand, without Bank Note Paper Mill India Private Limited having to substantiate its demand.

This guarantee will remain in force for a period of sixty days after the currency of this contract and any demand in respect thereof should reach the Bank not later than the above date.

.....



BG-PS

BANK NOTE PAPER MILL INDIA PRIVATE LIMITED

SECTION: XV

**BANK GUARANTEE FORM FOR PERFORMANCE
SECURITY**

SHEET 2 OF 2

(Signature of the authorized officer of the Bank)
Name, authorisation/ signature no. and designation of the officer
Seal, name & address of the Bank and address of the Branch



CF

BANK NOTE PAPER MILL INDIA PRIVATE LIMITED

SECTION: XVI

CONTRACT FORM

SHEET 1 OF 1

NOT APPLICABLE



	BANK NOTE PAPER MILL INDIA PRIVATE LIMITED	SECTION: XVII
LOA	LETTER OF AUTHORITY FOR ATTENDING A BID OPENING	SHEET 1 OF 1

(Refer to clause 24.2 of GIT)

The General Manager
Address

Subject: Authorization for attending bid opening on---- - ---(date) in the Tender of

Following persons are hereby authorized to attend the bid opening for the tender mentioned above on behalf (Bidder) in order of preference given below.

Order of Preference	Name	Specimen Signatures
1.		
2.		
Alternate Representative		
Signature of Bidder or Officer authorised to sign the bid on behalf of Bidder		

Note:

1. Maximum of two representatives will be permitted to attend bid opening. In cases where it is restricted to one, first preference will be allowed. Alternate representative will be permitted when regular representatives are not able to attend.
2. Permission for entry to the hall where bids are opened may be refused in case authorization as prescribed above is not produced.



SA

BANK NOTE PAPER MILL INDIA PRIVATE LIMITED

SECTION: XVIII

SHIPPING ARRANGEMENTS FOR LINER CARGOES

SHEET 1 OF 1

NOT APPLICABLE



PB

BANK NOTE PAPER MILL INDIA PRIVATE LIMITED

SECTION:XIX

PROFORMA OF BILLS FOR PAYMENTS

SHEET 1 OF 1

NOT APPLICABLE



**Instructions to the Applicants for Furnishing Information
As A Part of Pre-Qualifications Tender Notice**

1. Intending applicants are required to upload their full bio-data giving details about their organization, location of manufacturing units, experience, technical personnel in their organization, spare capacity competence and adequate evidence of their financial standing etc. in the enclosed format which will be kept confidential.
2. While deciding upon the selection of firms, great emphasis will be given on the ability and competence of applicants to do good quality works within the specified time schedule and in close coordination with other agencies, besides the rate structure of the items.
3. Decision of the Company in regard to selection of firms for issue of tender forms will be final. The Company is not bound to assign any reason thereof.
4. The application shall be signed by person / persons on behalf of the organization having necessary authorization / Power of Attorney to do so.
5. If the space in the proforma is insufficient for furnishing full details, such information may be supplemented on separate sheets of paper stating therein the part of the proforma and serial number. Separate sheets shall be used for each part.
6. Applications containing false and /or inadequate information are liable for rejection.

APQ

BANK NOTE INDIA PAPER MILL PRIVATE LIMITED

SECTION: XX

APPLICATION- PRE-QUALIFICATION

ANNEXURE - I
SHEET 2 OF 5

To:

Managing Director
Administrative Building,
Entry Gate 1, Paper Mill Compound,
Note Mudran Nagar,
Mysuru-570003, Karnataka, India

I / We have read and understood the Pre-qualification tender notice and instructions to the applicants and apply herewith for pre-qualification. . I / We furnish the information in the prescribed format including supplementary sheets fromfor your consideration. I/We do declare that the information furnished is correct and true to the best of my/our knowledge and belief.

Yours faithfully

Signature _____

Name:_____

Designation _____

Address _____

Seal _____

BASIC INFORMATION



APQ**BANK NOTE INDIA PAPER MILL PRIVATE LIMITED**

SECTION: XX

APPLICATION- PRE-QUALIFICATIONANNEXURE - I
SHEET 3 OF 5

1	Name of the applicant / organization and address of the registered office/business office.	
2	(a) Whether bidder is OEM (b) Address of the manufacturing facility in India	Yes / No
3	Type of the organization (whether Sole Proprietorship / Partnership / Private Limited / Limited or Cooperative Body etc).	
4	Name of the Proprietor / Partners / Directors of the Organization / Firm as the case may be.	(a) (b) (c)
5	Details of Registration – (whether Partnership firm, Company etc) – Name of Registering Authority, Date, Registration No etc.	
6	Whether registered with Government / Semi- Government / Municipal Authorities or any other Public Organization as a vendor and if yes provide details thereof.	
8	Experience in the field (Enclose documentary evidence)	____ Years
9	Address of office through which the proposed work will be handled and the name and designation of the Officer-in-charge.	
10	Names of Bankers and their full addresses	
11	Whether any civil suit / litigation arisen in the contracts executed during the last five years / being executed now. If yes, please furnish the details in the proforma given below.	



3. Details of Similar Works completed during last five years ending 31.12.2017.
Number of supplementary sheets attached.

Sl No	Description of work including the capacity of the equipment	Name & Address of Customer	PO No. /Agreement No with date	Qty of supply	Delivery period
1					
2					
3					
4					
5					

(Enclose the Customer certificate/Documentary evidence duly attested by authorised signatory)

4. Financial Details

Sl No	Financial Year	Average Annual Turn Over (Rs)	Profit (Rs)	Loss (Rs)
1	2017/ 2016-17			
2	2016/ 2015-16			
3	2015/2014-15			

(Enclose the certified/Audited copy of Profit and loss Account and Balance sheet as documentary evidence)

5. Has the applicant been blacklisted/ debarred by BNPMIPL/ BRBNMPL /SPMCIL or any Govt. Departments. Yes/NO

(If yes please provide the details.)

Signature of the Applicant _____

APQ

BANK NOTE INDIA PAPER MILL PRIVATE LIMITED

SECTION: XX

APPLICATION- PRE-QUALIFICATION

ANNEXURE - I
SHEET 5 OF 5

Name-----

Designation-----

Date-----

Stamp of the Organization-----



APQ

BANK NOTE INDIA PAPER MILL PRIVATE LIMITED

SECTION: XX

DECLARATION

ANNEXURE- I
SHEET 1 OF 1

(To be submitted on the letterhead)

DECLARATION

We do hereby declare that we have not been blacklisted/ debarred by BNPMIPL/ BRBNMPL/ SPMCIL or any Govt. Departments during last three years. The information provided above is correct and true to the best of my knowledge and belief. In case, at any time the information furnished is found to be false, you may disqualify/ debar me/ us as deemed fit.

Signature _____

Name-----

Designation-----

Date-----

Stamp of the Organization-----



APQ

BANK NOTE INDIA PAPER MILL PRIVATE LIMITED

SECTION: XX

DECLARATION

ANNEXURE- II
SHEET 1 OF 1

(To be submitted on the letterhead)

DECLARATION

We do hereby declare that we have read and understood all terms and conditions of tender document including GIT, SIT, GCC and SCC and confirm to abide to those conditions without any counter conditions.

Signature _____

Name-----

Designation-----

Date-----

Stamp of the Organization-----



Sl No	Description	Requirements of BNPMIPL, Terms & conditions	Ehether agreed by the firm (Yses/No)	Deviation if any
1.	General specifications	Items should be supplied exactly as per the given specifications mentioned in Section VII of the tender and have enclosed catalogue/brochure of the offered item	Yes/No	
2.	Quantity:	As per tender	Yes/No	
3.	Replacement of Rejection of materials	In case of rejection of material supplier shall replace the rejected material within 15 days on his cost	Yes/No	
4.	Delivery terms	As per section -VI	Yes/No	
5.	Payment terms	Payment terms as mentioned in the tender	Yes/No	
6.	Liquidated Damage	Liquidated Damage clause as mentioned in tender	Yes/No	
7.	Warranty	The items should be warranted against defects in material, design, workmanship etc. for a minimum period of 12 months from the date of supply and acceptance. During warranty period, the item should be replaced free of cost at our Store.	Yes/No	
8.	Tender terms & conditions	We have gone through entire tender document thoroughly including GIT (Section II - General Instructions to Tenderer), SIT (Section	Yes/No	

		III - Special Instructions to Tenderer), GCC (Section IV - General Conditions Of Contract), and SCC (Section V - Special conditions of contract) and confirm that we don't have counter conditions. We also understand that offer with counter conditions is liable for rejection		
9.	Customer Certificate/Documentary evidence in support of Technical pre-qualification criteria (Duly certified by signatory authority)	Purchase Order/ Work Order/ Agreement/ work completion certificate	Submitted/ Not submitted	
10.	Certified Copy of Audited Balance Sheet and Profit & loss accounts	FY 2016-17 FY 2015-16 FY 2014-15	Submitted/ Not submitted	
11.	Declaration	Declaration that firm is not debarred/blacklisted	Submitted/ Not submitted	
12.	Performance security / Security Deposit	As per tender	Yes/ No	
13.	Enviro-friendly Packing of Product	The product/item to be supplied should be packed in an environment- friendly manner	Yes / No	



Technical Specification compliance formate

		Offered by Bidders (Yses/No)	Deviation if any
Item	Blower Assembly		
Required air flow rate	10,000 m ³ / hr (min)		
Head	Min 385 mmwc to 450 mmwc		
Temperature at which air enters	Atmospheric temperature (25-30 ° C)		
Application	To convey cotton of 450 kg/ m ³ bulk density.		
Material flow rate	1500 Kg/hr		
Blower impeller	should be dynamically balanced with balancing certificate (existing impeller 560mm)		
No of blades on impeller	6 Nos		
MOC of the Impeller	MS / Aluminium Alloy		
MOC of blower casing	MS 5mm Thick		
Speed of motor	3000 RPM		
Motor Power	30 KW		
Suction Size	350mm ID circular as per drawing		
Delivery size	Rectangle shape 335 x 440 mm (as per drawing)		
Drive	Directly connected with motor shaft		
Dimensions	As per attached drawing		
MOC of Fan	MS ; 5mm thick (min)		
Paint of the Fan Body	Blue		
Motor Make	Siemens		

APQ

BANK NOTE INDIA PAPER MILL PRIVATE LIMITED

SECTION: XX

COMPLIANCE FORMAT - COMMERCIAL

ANNEXURE- III
SHEET 1 OF 1

Warranty	Minimum of 1 year		
Test certificate	Required		

Signature _____

Name-----

Designation-----

Date-----

Stamp of the Organization-----



ACW

BANK NOTE INDIA PAPER MILL PRIVATE LIMITED

SECTION XXI

ADDITIONAL CONDITIONS OF WORKS CONTRACT

SHEET 1 OF 1

NOT APPLICABLE TO THIS TENDER DOCUMENT



IP

BANK NOTE INDIA PAPER MILL PRIVATE LIMITED

ANNEXURE- XXII

INTEGRITY PACT

SHEET 1 OF 1

NOT APPLICABLE TO THIS TENDER DOCUMENT

